

Operating the Air Conditioner

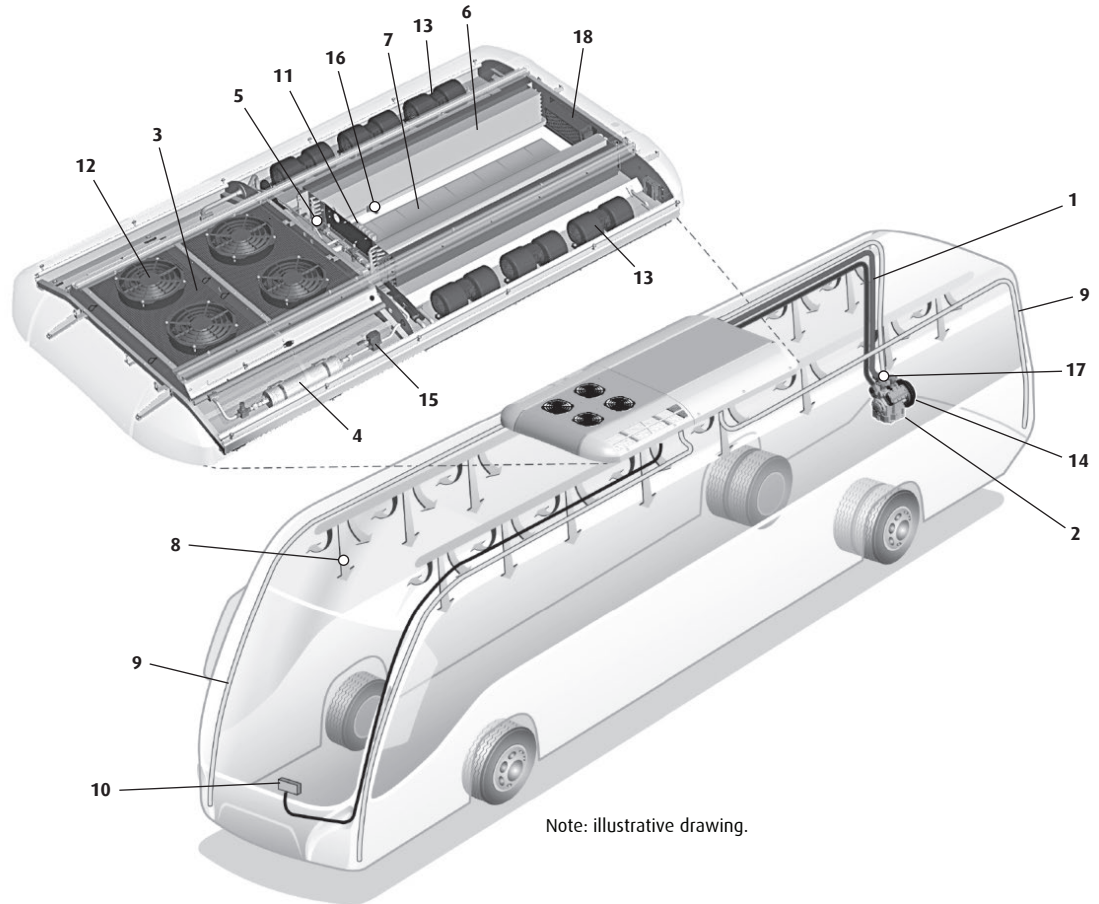
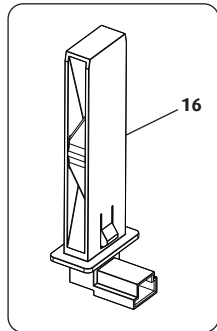
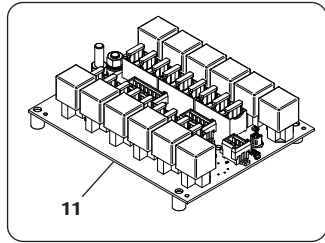

Note: illustrative drawing.

1 Refrigerant Fluid

It is inside the air conditioning equipment, inside the system. It works absorbing the heat from the interior / room of the vehicle, at the evaporator, and then it goes to the condenser where the heat is thrown to the outside. VALEO Climatização do Brasil - Veículos Comerciais S/A, products apply refrigerant R134a, according to the Protection Environmental Law.

2 Compressor

When it is working, the compressor sucks the refrigerant fluid from evaporator at gaseous state and under low pressure, compressing it, so temperature and pressure increase, then the compressor puts it into the condenser.

3 Condenser

Its main goal is dissipate the heat out, which was absorbed by the refrigerant fluid along the refrigeration system.
At the condenser, the overheat refrigerant fluid is sent to outside losing its force, changing from gaseous state to liquid state.

4 Drier filter

Tiene la finalidad de retener impurezas y/o humedad que pueda haber en el sistema impidiendo que lleguen en la válvula de expansión.

5 Expansion Thermostatic Valve

Valve hinders the refrigerant inlet that comes from de condenser at high pressure and its goal is adjust the refrigerant gas flow that passed by the evaporator looking for making the pressure steady and temperature at the capillary tubes output.

6 Evaporators

Now at evaporators, the refrigerant fluid, at low pressure, turns from liquid to gaseous state, absorbing the interior heat of the vehicle in this process.

7 Air filter

Air return filter retains impurities from air avoiding any block of dirt at evaporator capillary tubes and coil.

8 Air circulation

Air being cooled by the evaporator, then it follows to the bus interior through fans.

9 Drain

It is a way to get the condensed moisture from evaporator tubes from the condensed tray to putting out.

10 Controller

It is installed in the instrument panel, it offers to the driver to set-point of temperature, to see by display the interior temperature, offering full climatic control inside de bus.

Set-point: it is the temperature the driver wishes to set inside the vehicle for passengers.

11 Relay Board

Relay board has the controller controls, condenser fan control, evaporator control and compressor control.

12 Condenser Fan

Condenser fan and the compressor will only work at "Cool Mode".

13 Evaporator Fan

Evaporator fans are working at cool and fan modes, fans can be set in two speeds.
Sped control can be manual or automatic.

14 Compressor Operation

It is started up by the vehicle engine though a pulley-and-belt system and put into action by an electromagnetic clutch when air conditioning is operating at "Cool Mode".

15 Solenoid Valve

Solenoid valve is applied to stop refrigerant flow through a line. It is a closing valve controlled remotely and under electric operation.

16 Temperature Sensor

The interior temperature is measured by the temperature sensor placed at the air return spot.

17 Pressure Switches

Pressure switches are electric devices that monitor the air conditioning equipment operation pressure. Every time a strong change happens from the NORMAL temperature, they turn off the compressor immediately to avoid break.
Observation: pressures are always monitored, even if the air conditioning is turned off.

18 Air refreshment

This permits the entry of the external in order to expel unwanted odors and impurities from the vehicle.